

FIGURE 1.
*18 lbs TIES DO NOT HAVE A PRE-LOCK FEATURE

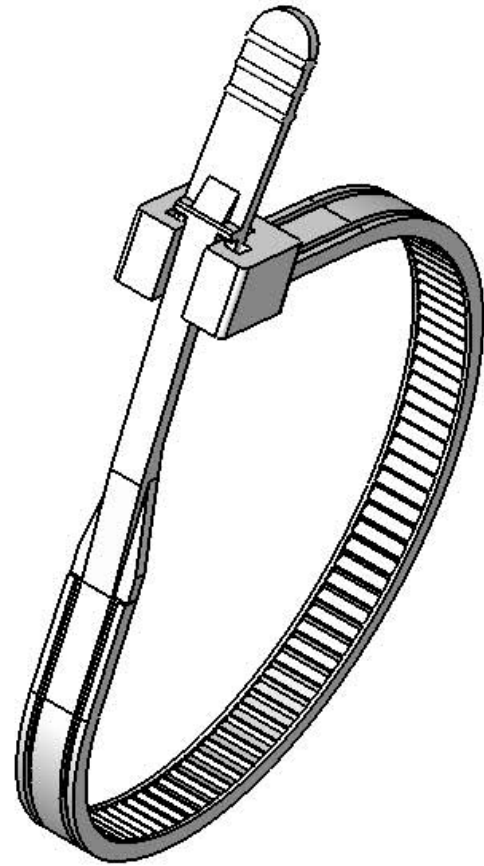
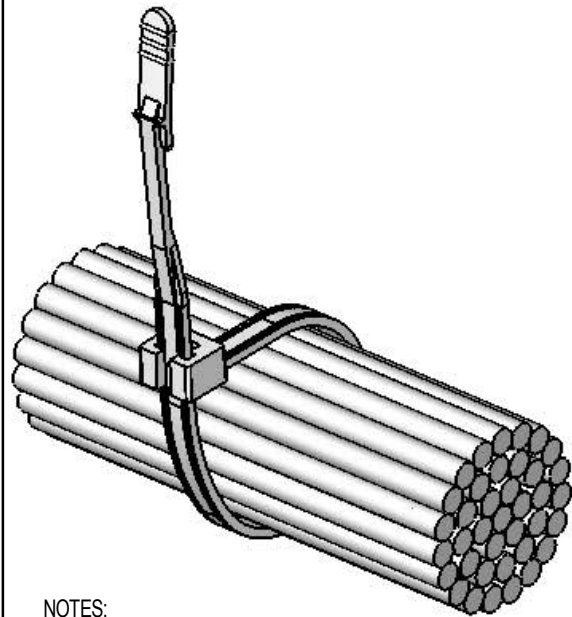

FIGURE 2.
(AT PRE-LOCK POSITION)



NOTES:
1. PART DESIGNED IN mm, INCH CONVERSION FOR REFERENCE ONLY

A	RELEASED FOR PRODUCTION	SK	10/27/05
REV.	DESCRIPTION	ENGR.	DATE

MATERIAL: NYLON 6/6 UL 94 V-2 (RMS-220), NATURAL. PART NO.	MATERIAL: UV STABILIZED NYLON 6/6 UL 94 V-2 (RMS-221), BLACK. PART NO.	MAXIMUM BUNDLE DIA.	LENGTH "L" APPROX.	"A"	"B"	"T" REF	"W" REF	MIN. LOOP TENSILE lbs [kg]	FIGURE NO.
*QTE-18R	QTE-18R-UVB	24 [.945]	105 [4.134]	3.7 [.146]	5 [.197]	1 [.039]	2.6 [.102]	18 [8]	1
*QTE-18L	QTE-18L-UVB	40 [1.575]	155 [6.102]	3.7 [.146]	5 [.197]	1 [.039]	2.6 [.102]	18 [8]	1
*QTE-18V	QTE-18V-UVB	50 [1.969]	195 [7.677]	3.7 [.146]	5 [.197]	1 [.039]	2.6 [.102]	18 [8]	1
QTE-30R	QTE-30R-UVB	38 [1.496]	160 [6.299]	4.6 [.181]	7 [.276]	1.3 [.051]	3.6 [.142]	30 [13]	2
QTE-30L	QTE-30L-UVB	50 [1.969]	200 [7.874]	4.6 [.181]	7 [.276]	1.3 [.051]	3.6 [.142]	30 [13]	2
QTE-30XL	QTE-30XL-UVB	65 [2.559]	250 [9.843]	4.6 [.181]	7 [.276]	1.3 [.051]	3.6 [.142]	30 [13]	2
QTE-30VL	QTE-30VL-UVB	82 [3.228]	300 [11.811]	4.6 [.181]	7 [.276]	1.3 [.051]	3.6 [.142]	30 [13]	2
QTE-50R	QTE-50R-UVB	50 [1.969]	210 [8.268]	5.4 [.213]	9 [.354]	1.4 [.055]	4.7 [.185]	50 [22]	2
QTE-50RL	QTE-50RL-UVB	75 [2.953]	290 [11.417]	5.4 [.213]	9 [.354]	1.4 [.055]	4.7 [.185]	50 [22]	2
QTE-50L	QTE-50L-UVB	110 [4.331]	410 [16.142]	5.4 [.213]	9 [.354]	1.4 [.055]	4.7 [.185]	50 [22]	2
QTE-120SL	QTE-120SL-UVB	70 [2.756]	300 [11.811]	7.6 [.299]	13.2 [.520]	1.8 [.072]	7.7 [.303]	120 [54]	2
QTE-120R	QTE-120R-UVB	110 [4.331]	420 [16.535]	7.6 [.299]	13.2 [.520]	1.8 [.072]	7.7 [.303]	120 [54]	2
QTE-120L	QTE-120L-UVB	145 [5.709]	520 [20.472]	7.6 [.299]	13.2 [.520]	1.8 [.072]	7.7 [.303]	120 [54]	2

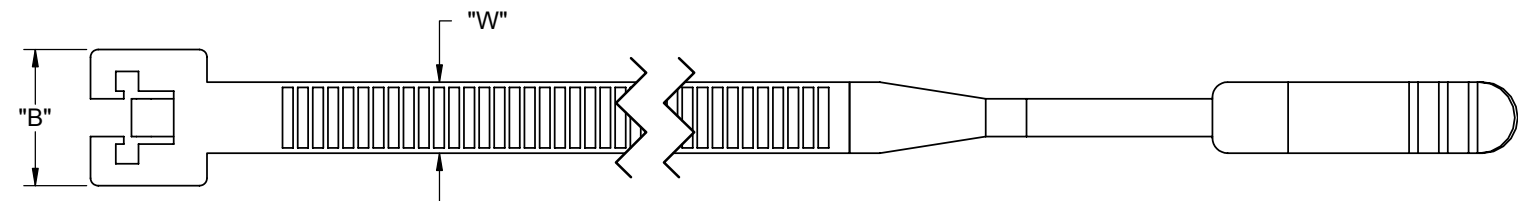
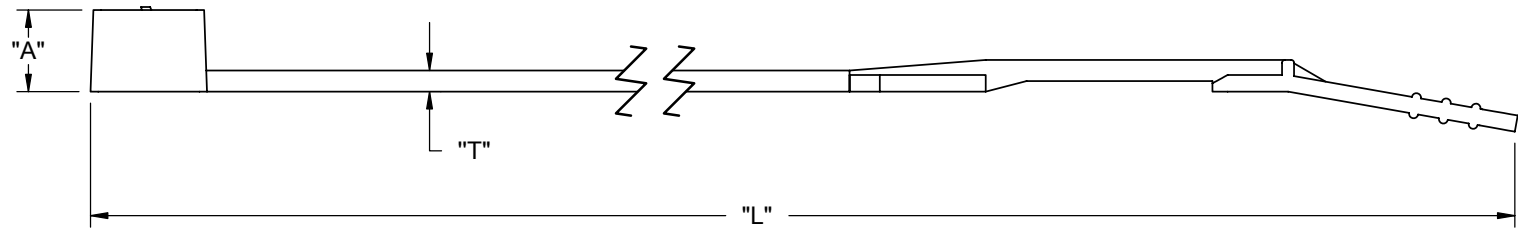

TITLE: Q-TIE				DWG IN mm [IN]		FINAL	
CREATED USING SOLIDWORKS	FILE #: QTE	DWN: SK	APP: BR	FINAL			
GENERAL TOLERANCE UNLESS OTHERWISE NOTED ±0.25	SHEET: 1 OF 1	SHEET SIZE: B	DT: 10/26/05	CHKD: DZ	PART #		PRINT TYPE
RE: RICHCO, INC.		RICHCO, INC. ENG@RICHCO-INC.COM (773) 539-4060		SEE TABLE		CA	